

samiflex[®]

**ELASTIC
COUPLING**

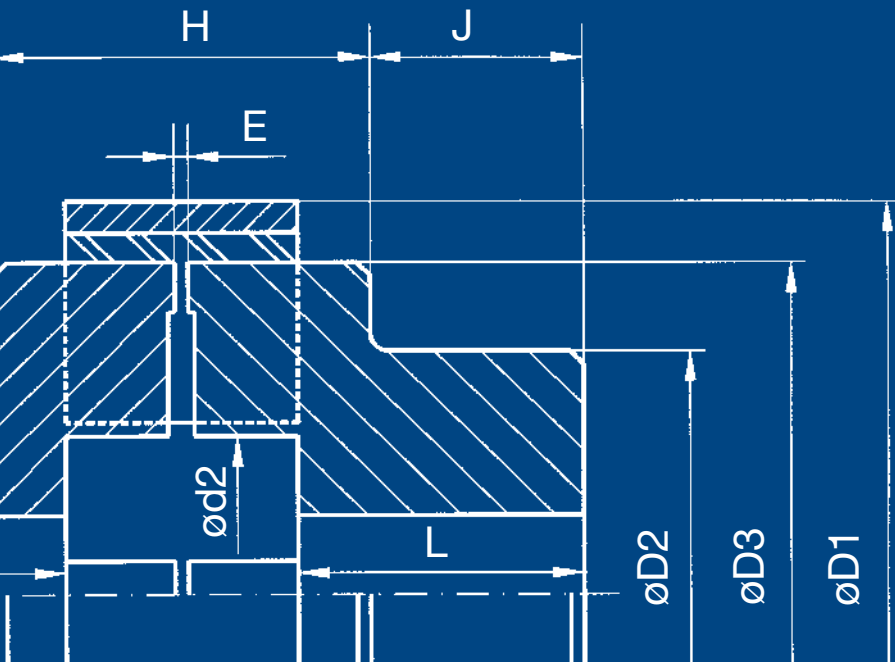

STANDARD COUPLING
TYPE A and C



PAG. 3

BRAKEWHEEL COUPLING
TYPE PF

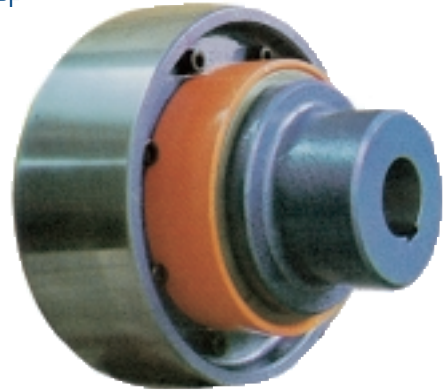

PAG. 8

STANDARD COUPLING FOR TAPER BUSH
TYPE TB



PAG. 10

FLYWHEEL COUPLING
TYPE EB



PAG. 9

SPACER COUPLING
TYPE A and C



PAG. 7

DISC COUPLING
TYPE DF



PAG. 8

SPACER COUPLING
TYPE DL



PAG. 6



SAMIFLEX ELASTIC COUPLING

The new **SAMIFLEX elastic coupling** is the result of the experience and development of the last twenty seven years of involvement in all industrial sectors.

The new **SAMIFLEX** couplings are characterized by:

1. The option of attaching the ring to the elastic insert to prevent it moving axially.
2. The option of working vertically, using the standard retaining ring and the new design of elastic insert.
3. Expansion of the range of polyurethane elastic inserts, colour coded according to characteristic and performance. We would highlight the high performance elastic insert, with which we have increased the torque rating by 40%.
4. Limited end float coupling for all sleeve bearing motor applications. One of the major advantages of this coupling is that the standard hub can be easily modified for this requirement.
5. Increase of the performance, with the incorporation of the new models A45, A55 and A11.
6. Expansion of the range of materials used in the standard design, incorporating high resistance aluminium alloy, stainless steel, high performance polyurethane, shock-resistant polyamide and carbon fibre composites.

DESCRIPTION

There are only four parts to SAMIFLEX couplings.

The two identical hubs (1) and (2) are made from high-strength cast iron, ductile iron, cast steel or aluminium alloy, each with eight teeth, (except for the A0 and A00, which have six and four respectively).

The elastic insert (3), which is made from a special polyurethane elastomer, fits between the hubs.

The outer retaining ring (4) is made of steel or polyamide, with interior pins for adjusting this ring on the elastic insert. The ring also has two threaded holes, symmetrical to each other, through which two set screws can be fitted. The set screws are aligned to a mating holes in the elastic insert and once secured ensures that the ring can not move during operation (see. fig. 3).

ASSEMBLY AND DISASSEMBLY

After machining the bores, the hubs (1) and (2) are fitted onto the shafts.

Note, the retaining ring should be located over the shaft prior to setting the DBSE (Distance Between Shaft Ends) and aligning.

The teeth of the hubs are positioned facing each other, to the correct gap (E). The elastic insert (3) can then be installed in the slots formed by the parallel teeth.

When the insert is in position, slide the ring (4) onto the polyurethane insert, tapping gently into place with soft-headed hammer, until the ring's inner pin falls into place in center hole of insert. Centrifugal force will expand the elastic insert to fix it tightly to the inside of the ring.

If the alignment cannot be kept within the admissible tolerance, the ring can be secured using locking set screws (fig. 3).

To disassemble, remove the ring. The insert can then be quickly and easily removed and replaced. No special tools, screws, bolts or other fasteners are needed.

SAMIFLEX MEANS SAVING IN MANPOWER AND DOWNTIME, EASY OF INSTALLATION, ECONOMY AND LONG, TROUBLE-FREE SERVICE.

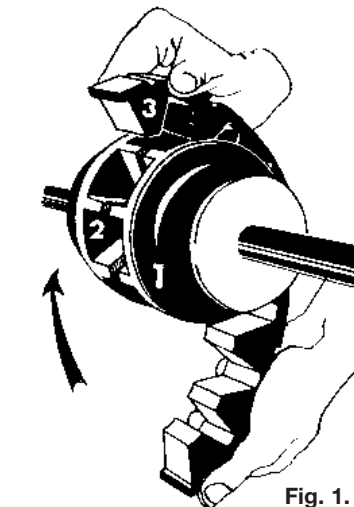

Fig. 1.

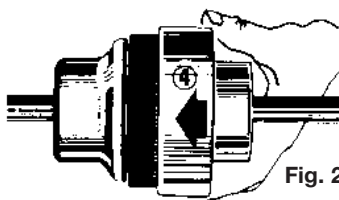

Fig. 2.

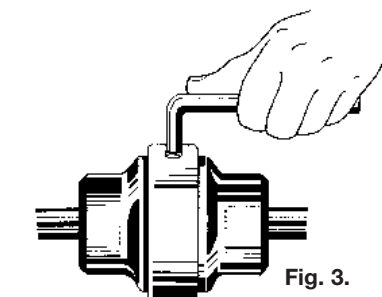

Fig. 3.

FEATURES AND BENEFITS

- Assembly and disassembly of the elastic insert without having to displace the motor or the unit being driven. This advantage permits the inspection of the insert at any time without a lengthy shut-down. Simply displace (move to one side) the ring, remove the insert, inspect and if necessary replace with a new one. All this takes a few minutes.

- The two hubs work independently as the coupling transmits torque. This concept allows free-wheeling of the motor or driving unit in the system by simply moving the ring and removing the insert. This is specially helpful when the driving unit is a combustion engine and it becomes necessary to repair or test the engine without any load.

- As the hubs are independent of each other, if the insert ruptures or breaks, there is no metal to metal contact creating any spark thus enhancing the explosion proof properties of the coupling.

- The polyurethane insert is a key part of the coupling and is made of a very special elastomer compound. Its estimated average lifetime is 25,000 hours work under normal conditions.

- The coupling is easily aligned without expensive tools or measuring devices (see our installation instructions).

MISALIGNMENT ADMISSABLE

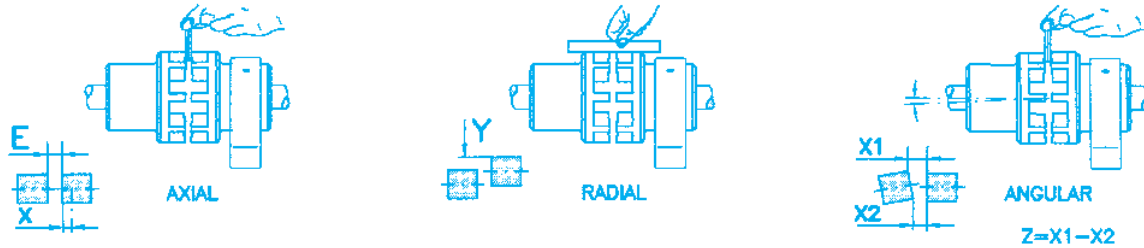

Assembly dimensions (E) and tolerances in mm

Type	A00	A0	A1	A2	A3	A4	A45	A5	A55	A6	A7	A8	A9	A10	A11
E Assembly	1,5	1,5	1,5	2,5	2,5	3,5	3,5	3,5	3,5	3,5	4	5	5	6	6
AXIAL X	+0,3	+0,3	+0,5	+0,5	+0,7	+0,8	+1,0	+1,0	+1,0	+1,0	+1,0	+1,5	+1,5	+2	+2
RADIAL Y	0,1	0,1	0,1	0,1	0,15	0,20	0,20	0,20	0,20	0,20	0,30	0,30	0,30	0,40	0,40
ANGULAR Z	0,10	0,10	0,20	0,20	0,30	0,40	0,40	0,50	0,50	0,60	0,90	1,10	1,30	1,70	1,70

COUPLING SELECTION

FACTOR F1

DRIVEN MACHINE / EXAMPLES	ELECTRIC MOTOR	DIESEL AND PETROL ENGINES	
		4 - 6 CYLINDERS	1 - 3 CYLINDERS
Uniform operation, with small masses to be accelerated. Hydraulic and centrifugal pumps, light generators transmissions ventilators, transfer equipment.	1,0-1,2	1,5	2,0
Uniform operation, with medium masses to be accelerated. Sheet metal bending machines, wood working machines, mills, textiles machines, mixers.	1,5	1,8	2,5
With medium masses to be accelerated and irregular operation. Rotating ovens, printing and colour machines, generators, shredders, winders, pumps for viscous fluids.	1,8	2,0	2,8
With medium masses to be accelerated, irregular operation and shocks. Concrete mixers, drop hammers, cable cars, paper mills, compression pumps, propeller pumps, rope winders, centrifuges.	2,0	2,5	3,0
Large masses to be accelerated, irregular operation and heavy shocks. Excavators, hammer mills, piston pumps, presses, rotary boring machines, shears, forge presses, stamping presses.	2,2	2,8	3,5
Very large masses to be accelerated, irregular operation and very heavy shocks. Piston type compressors and pumps without speed variations, heavy roll sets, welding machines, brick presses, stone crushers.	2,5	3,0	3,8

FACTOR F2

	OPERATION PERIOD HOURS / DAY		
MORE THAN UP TO			
	2	12	24
FACTOR F2	1	1,15	1,3

FACTOR F3

	STARTS PER HOURS				
MORE THAN UP TO					
	10	40	120	200	200
SWITCHINGS PER HOUR	1	1,25	1,75	2,5	3

METHOD

Data needed to correctly select coupling size.

- Kw of driver.
- R.p.m. of driver
- Service coefficient F, (see below).
- Shaft size of driver and driven equipment.

(1) Calculate the nominal torque (Pn) in Nm.

$$P_n = \frac{7.160 \times \text{H.P.}}{\text{r.p.m.}} \quad P_n = \frac{9.550 \times \text{Kw}}{\text{r.p.m.}}$$

(2) Use figures obtained from tables F1, F2 and F3 to determine the service coefficient F.

$$F = F_1 \times F_2 \times F_3$$

Calculate the maximum torque (Pc) $P_c = P_n \times F$

(3) In the TECHNICAL DETAIL SAMIFLEX COUPLING table, obtained nominal torque and maximum torque for each size coupling.

Select size the coupling whose nominal torque is higher than Pn, or whose maximum torque is higher than Pc.

EXAMPLE

Electric motor – 55 Kw
R.P.M. – 1.500
Shaft motor – 65 mm.
Shaft pump – 48 mm.
Driven equipment – Centrifugal pump.
Working 24 hours per day.

$$P_n = \frac{9.550 \times 55}{1.500} = 350 \text{ Nm}$$

F1 = 1,2

F2 = 1,3

F3 = 1

$$F = F_1 \times F_2 \times F_3 = 1,2 \times 1,3 \times 1 = 1,56$$

$$P_c = P_n \times F = 350 \times 1,56 = 546 \text{ Nm}$$

Select size A4

Nominal torque = 400 Nm

Maximum torque = 1.000 Nm

Max. bore = 65 mm.

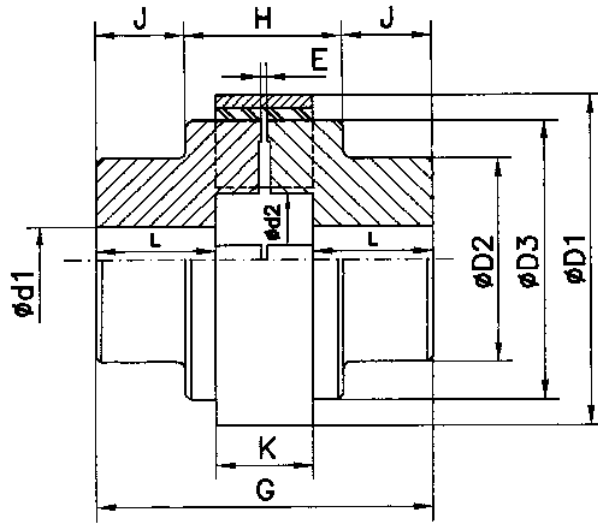

TECHNICAL DETAIL AND DIMENSIONS (mm.)

COUPLING TYPE	A00	A0	A1	A2	A3	A3B	A4	A4B	A45	A5	A55	A6	A7	A8	A9	A10	A11
NOMINAL KW PER 1.000 RPM	0,70	2	5,5	10,5	21	21	42	42	74	105	157	210	420	785	1.310	2.620	3.670
NOM. TORQUE (TKn) Nm	6,5	20	50	100	200	200	400	400	700	1.000	1.500	2.000	4.000	7.500	12.500	25.000	35.000
MAX. TORQUE (TKmax.) Nm	20	50	90	250	500	500	1.000	1.000	1.750	2.500	3.000	4.000	8.000	15.000	25.000	40.000	56.000
MAX. SPEED R.P.M.	9.000	9.000	8.000	6.500	4.800	4.800	3.500	3.500	3.100	2.900	2.600	2.500	2.200	1.850	1.600	1.250	1.250
TORSIONAL STIFFNESS (CTdyn) 10^9Nm. rad^{-1}	0,21	0,32	0,95	2,1	4,2	4,2	9,5	9,5	11,2	16	42	65	112	200	214	460	580
RELATIVELY DAMPING (ψ)	0,65	0,65	0,65	0,65	0,65	0,65	0,65	0,65	0,65	0,65	0,65	0,65	0,65	0,65	0,65	0,65	0,65
MOMENT OF INERTIA J(Kg-m ²)	-	-	0,001	0,005	0,012	0,02	0,05	0,075	0,102	0,155	0,275	0,437	0,825	2,325	4,95	12	16
Weight Kg	0,2	1,0	1,8	3,8	6,2	8,5	12,5	16	19	26	36	47	74,5	137	218	350	410

COUPLING TYPE	A00	A0	A1	A2	A3	A3B	A4	A4B	A45	A5	A55	A6	A7	A8	A9	A10	A11
MAX. BORE d1	16	23	38	42	50	55	65	70	75	85	95	110	130	150	180	210	210
PRE BORE	4	8	14	17	19	19	24	24	25	29	30	39	48	63	73	96	96
G	51	73	91	127	156	156	180	180	198	216	246	260	310	382	420	482	512
L	19	28	34	47	56	56	63	63	70	77	90	95	116	147	162	188	190
d2	22	32	39	45	52	52	70	70	90	89	115	112	135	157	188	218	216
D1	44	65	83	111	144	144	182	182	202	225	250	265	306	363	425	523	503
D2	35	52	65	80	85	105	110	135	125	140	155	180	205	242	280	330	350
D3	35	52	65	86	116	116	150	150	170	190	215	233	267	326	385	483	458
K	12	16	22	32	42	42	51	51	56	59	64	67	75	85	92	102	128
J	-	-	-	36	45	45	47	47	52	57	68	70	88	114	129	145	148
H	-	-	-	55	65	65	85	85	93	101	109	119	134	154	162	192	216
E	1,5	1,5	1,5	2,5	2,5	2,5	3,5	3,5	3,5	3,5	3,5	3,5	4	5	5	6	6

* Nominal torque / Maximum torque, with Standard elastic insert hardness 95 Shore A (yellow colour).

High performance inserts. Reference HD (ochre colour), enable the torque rating to be increased by 40%.

Please consult us.

• Hubs material: cast iron GG-25 / ductile iron GGG-40 / cast steel GS-45 / stainless steel AISI 316 / aluminium alloy C135 (ALCAN).

• Unless that quality is specified in advance, supply is made with hubs material GG-25 and insert 95 shore A.

COUPLING SELECTION SAMIFLEX COUPLINGS FOR I.E.C. STANDARD MOTORS

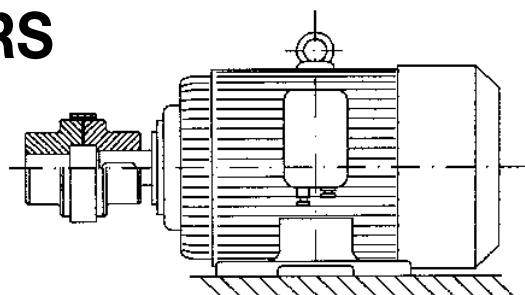

MOTOR SIZE	SPEED 3.000 R.P.M.				SPEED 1.500 R.P.M.				SPEED 1.000 R.P.M.				SPEED 750 R.P.M.			
	MOTOR		COUPLING		MOTOR		COUPLING		MOTOR		COUPLING		MOTOR		COUPLING	
	KW	Ø SHAFT	TYPE	Ø MAX. BORE	KW	Ø SHAFT	TYPE	MAX. BORE	KW	Ø SHAFT	TYPE	MAX. BORE	KW	Ø SHAFT	TYPE	MAX. BORE
71	0,37 0,55	14	A00	16	0,25 0,37	14	A00	16	0,25	14	A00	16	-	-	-	-
80	0,75 1,1	19	A0	24	0,55 0,75	19	A0	19	0,37 0,55	19	A0	24	-	-	-	-
90S	1,6	24	A0	24	1,1	24	A0	24	0,75	24	A0	24	0,37	24	A0	24
90L	2,2	24	A0	24	1,5	24	A0	24	1,1	24	A0	24	0,55	24	A0	24
100L	3	28	A1	38	2,2 3	28	A1	38	1,5	28	A1	38	0,75 1,1	28	A1	38
112M	4	28	A1	38	4	28	A1	38	2,2	28	A1	38	1,5	28	A1	38
132S	5,5 7,5	38	A1	38	5,5	38	A1	38	3	38	A1	38	2,2	38	A1	38
132M	-	-	-	-	7,5	38	A1	38	4 5,5	38	A1	38	3	38	A1	38
160M	11 15	42	A2	42	11	42	A2	42	7,5	42	A2	42	4 5,5	42	A2	42
160L	18,5	42	A2	42	15	42	A2	42	11	42	A2	42	7,5	42	A2	42
180M	22	48	A3	50	18,5	48	A3	50	-	-	-	-	-	-	-	-
180L	-	-	-	-	22	48	A3	50	15	48	A3	50	11	48	A3	50
200L	30 37	55	A3B	55	30	55	A3B	55	18,5 22	55	A3B	55	15	55	A3B	55
225S	-	-	-	-	37	60	A4	65	-	-	-	-	18,5	60	A4	65
225M	45	55	A3B	55	45	60	A4	65	30	60	A4	65	22	60	A4	65
250M	55	60	A4	65	55	65	A4	65	37	65	A4	65	30	65	A4	65
280S	75	65	A4	65	75	75	A45	75	45	75	A45	75	37	75	A45	75
280M	90	65	A4	65	90	75	A45	75	55	75	A45	75	45	75	A45	75
315S	110	65	A4	65	110	80	A5	85	75	80	A5	85	55	80	A5	85
315M	132	65	A45	75	132	80	A5	85	90	80	A5	85	75	80	A5	85
355S	160	70	A45	75	160	90	A55	95	110 132	90	A55	95	90 110	90	A55	95
355M	200	70	A45	75	200	90	A55	95	160	90	A55	95	132	90	A55	95
400S	-	-	-	-	250	100	A6	110	200	100	A6	110	160	100	A6	110
400M	-	-	-	-	315	100	A6	110	250	100	A7	130	200	100	A7	130

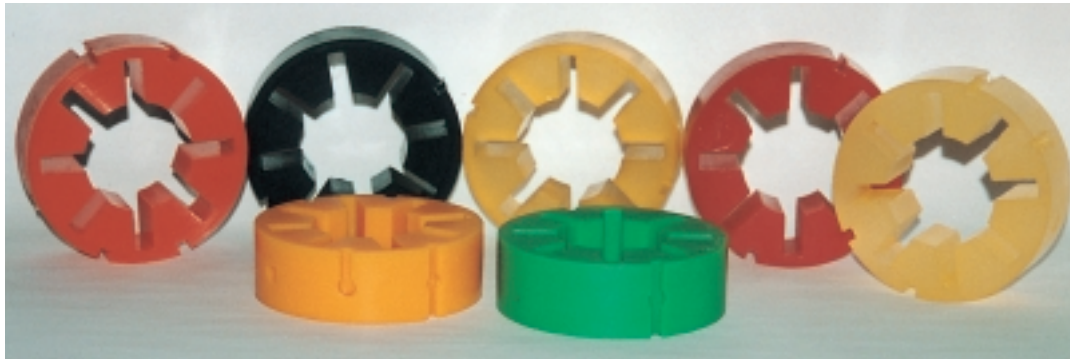

THE ELASTIC INSERT SAMIFLEX

The elastic insert is made of a very special polyurethane elastomer compound which is manufactured to an exceptional quality, providing all the required characteristics of a high performance elastic coupling.

- High breakage and shearing resistance, and tensile strength.
- High shock-absorbing capacity, stable, constant resistance.
- High resistance to abrasion, humidity, oils, corrosive vapours and numerous chemical products.
- Stability of the performance characteristics from -40 °C to 80 °C for standard manufacture insert. We manufacture elastic inserts (type HT) for applications between -40 and 140 °C.
- Excellent resistance providing a long life in abrasive, corrosive, humid atmospheres, all without lubrication or maintenance.

Samiflex elastic inserts are manufactured in three qualities and five hardnesses, depending on the application.

QUALITY	REF.	HARDNESS	COLOUR	TEMP. RATING
STANDARD	STD	80 Shore A	CLEAR	-40 / 80° C
		90 Shore A	BLUE	
		95 Shore A	YELLOW	
HIGH TEMP.	HT	95 Shore A	ORANGE	-40 / 140° C
HIGH PERFORMAN.	HD	97 Shore A	OCHRE	-40 / 80° C
	HDT	97 Shore A	RED	-40 / 140° C
	HR	65 Shore D	GREEN	-40 / 140° C

Unless that quality is specified in advance, supply is made with standard elastic insert, hardness 95 Shore A, yellow colour.

High-performance inserts. Reference HD and HDT, ochre and red respectively, enable the torque rating to be increased by 40%. **Please consult the factory.**

The elastic insert has three types of symmetrical slots. **Fig. 1.**

Slot 1, for inserting the pins of the holding ring in horizontal assembly.

Slot 2, for inserting the pins of the holding ring in vertical assembly.

Slot 3, optional application, enabling two set screws to be inserted through two tapped holes in the holding ring to prevent axial movement of this rings.

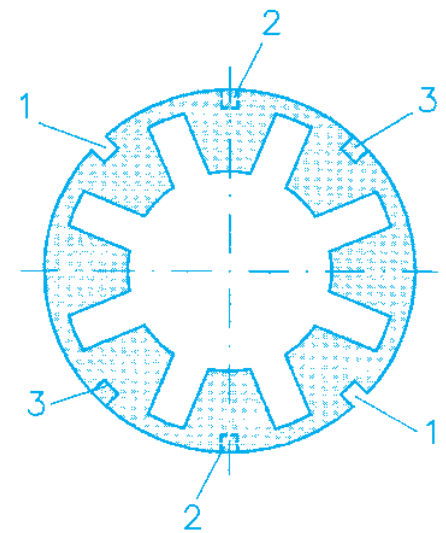
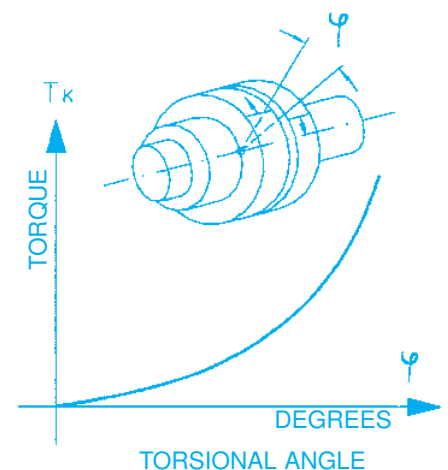
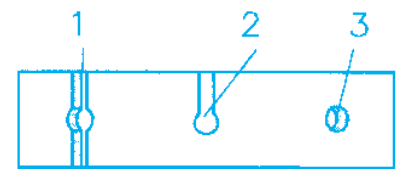

FIG. 1



HARDNESS Shore	ELASTIC INSERT / TORSIONAL STIFFNESS 10 ³ Nm. rad ⁻¹												
	A1	A2	A3	A4	A45	A5	A55	A6	A7	A8	A9	A10	A11
80 A	0,22	0,50	1,05	1,90	2,04	2,85	7,50	10,80	19,35	33,50	39,70	74,20	92,70
90 A	0,43	1,08	2,00	4,35	5,30	7,25	19,00	30,90	50,80	95,20	101,90	209,00	250,00
95 A	0,95	2,10	4,20	9,50	11,20	16,00	42,00	65,00	112,00	200,00	214,00	460,00	580,00
97 A	1,71	3,78	7,56	17,10	20,16	28,80	79,80	123,50	212,80	380,00	406,00	874,00	1.095,00
65 D	2,37	5,25	10,50	23,75	28,00	40,00	109,20	169,00	291,20	520,00	556,00	1.196,00	1.480,00

HINTS FOR INSTALLATIONS IN HAZARDOUS AREAS



II 2G C IIC T4
II 2D C T4

According with the directive ATEX 94/9/EC, shaft couplings are classified as units to be part of a equipment, under the non-electrical material group.

The Samiflex elastic coupling, meet all the ATEX conformity requirements for group II, category 2G (gas) and 2D (dust), explosion group IIC and temperature T4.

Installation instructions for the Samiflex coupling with ATEX certification are published in our bulletin 07/2003 and are available to consult and download in our websites www.samiflex.com and www.citsa.com

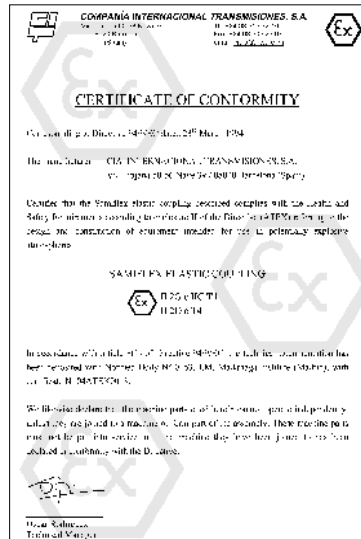

SAMIFLEX SPACER COUPLINGS

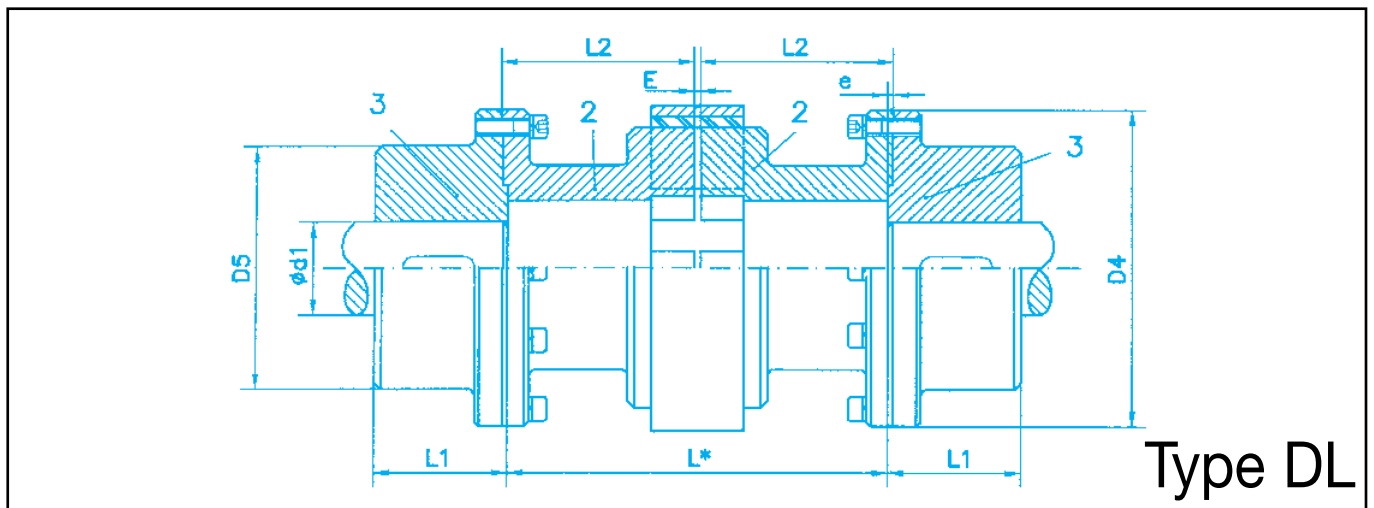

TYPE	NOMINAL TORQUE Nm	MAX. TORQUE Nm	MAX. SPEED R.P.M.	MAX. BORE d1 mm.	D5 mm.	D4 mm.	E mm.	e mm.	L1 mm.	L2 mm.	L* mm.
A4 DL	400	1.000	3.500	85	140	178	3,5	2,5	85	90,8 125,8 150,8	180 250 300
A45 DL	700	1.750	3.500	90	150	200	3,5	2,5	95	90,8 125,8 150,8	180 250 300
A5 DL	1.000	2.500	3.000	110	179	225	3,5	2,5	105	125,8 150,8	250 300
A55 DL	1.750	3.000	3.000	110	180	245	4	3	110	126 151	250 300
A6 DL	2.000	4.000	2.500	120	198	265	4	3	130	126 201	250 400
A7 DL	4.000	8.000	2.500	130	230	290	4	3	150	201 251	400 500

- MATERIAL (ITEMS 2+3): DUCTILE IRON GGG40.
- DYNAMIC BALANCING, GRADE 6.3 S/VDI 2060.
- STANDARD SIZES IN STOCK. - CONSULT FACTORY FOR SPECIAL SIZES.

SAMIFLEX SPACER COUPLINGS

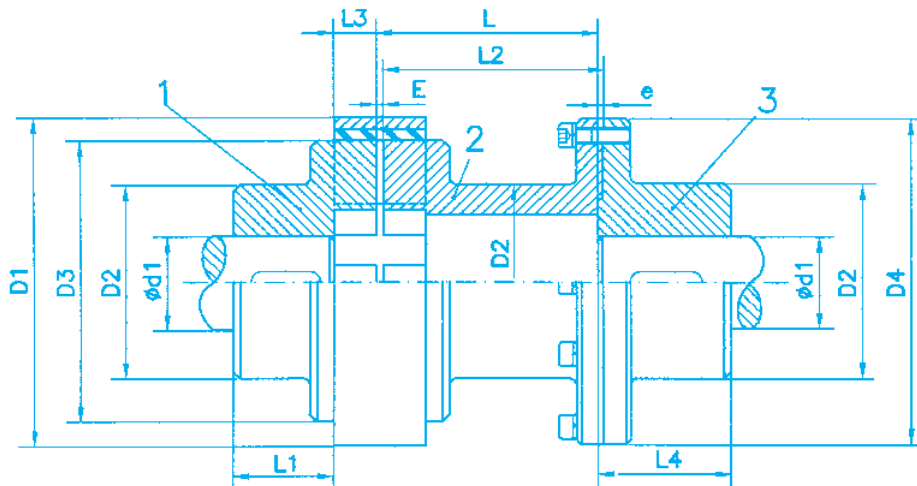
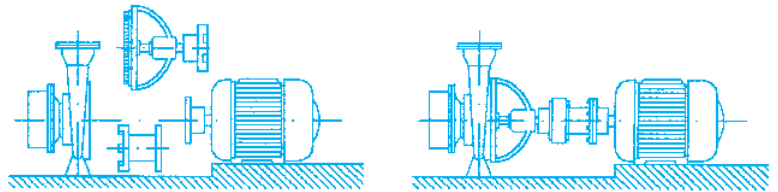

Type A

TYPE	NOMINAL TORQUE Nm	MAX. TORQUE Nm	MAX. BORE d1 mm.	MAX. SPEED R.P.M.	D1 mm.	D2 mm.	D3 mm.	D4 mm.	E mm.	e mm.	L1 mm.	L4 mm.	L3 mm.	L2 mm.	L mm.		
A1	50	90	38	5.500	83	65	65	100	3	2	34	37	10	L-1	100	120	140
A2	100	250	42	5.000	111	80	86	120	3	2	47	54	15	L-1	100	120	140
A3	200	500	50	4.500	144	85	116	140	3,5	2,5	56	60	20	L-1	100	120	140
A4	400	1.000	65	3.500	182	110	150	178	3,5	2,5	63	65	25	L-1	120	140	180
A45	700	1.750	75	3.100	202	125	170	200	3,5	2,5	70	75	27	L-1	120	140	180
A5	1.000	2.500	85	2.900	225	140	190	225	3,5	2,5	77	79	29	L-1	140	180	200
A55	1.500	3.000	95	2.600	250	155	215	245	4	3	90	95	31	L-1	140	180	200
A6	2.000	4.000	110	2.500	265	180	233	265	4	3	95	95	33	L-1	180	200	250
A7	4.000	8.000	130	2.200	306	205	267	290	4	3	116	120	37	L-1	200	250	280

PUMP
SIDE

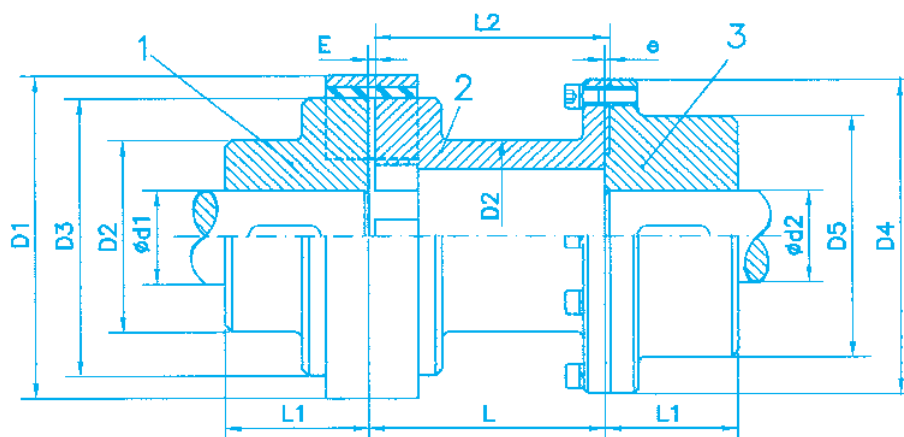

MOTOR
SIDE

Type C

TYPE	NOMINAL TORQUE Nm	MAX. TORQUE Nm	MAX. BORE d1 mm.	MAX. BORE d2 mm.	MAX. SPEED R.P.M.	D1 mm.	D2 mm.	D3 mm.	D4 mm.	D5 mm.	E mm.	e mm.	L1 mm.	L2 mm.	L mm.			
A1C	50	90	28	42	5.500	83	65	65	100	67	3	2	45	L-1	100	120	140	
A2C	100	250	35	48	5.000	111	80	86	120	83	3	2	62	L-1	100	120	140	
A3C	200	500	42	65	4.500	144	85	116	140	107	3,5	2,5	76	L-1	100	120	140	180
A4C	400	1.000	55	85	3.500	182	110	150	178	140	3,5	2,5	88	L-1	100	120	140	180
A45C	700	1.750	65	90	3.100	202	125	170	200	150	3,5	2,5	97	L-1	100	120	140	180
A5C	1.000	2.500	75	110	2.900	225	140	190	225	179	3,5	2,5	106	L-1	140	180	200	250
A55C	1.500	3.000	75	110	2.600	250	155	215	245	180	4	3	121	L-1	140	180	200	250
A6C	2.000	4.000	90	120	2.500	265	180	233	265	198	4	3	128	L-1	180	200	250	280
A7C	4.000	8.000	110	130	2.200	306	205	267	290	230	4	3	153	L-1	180	200	250	280

REF. 1-2-3, MATERIAL: CAST IRON GG-25 / DUCTILE IRON GGG-40.

SAMIFLEX BRAKEWHEEL AND DISC COUPLING

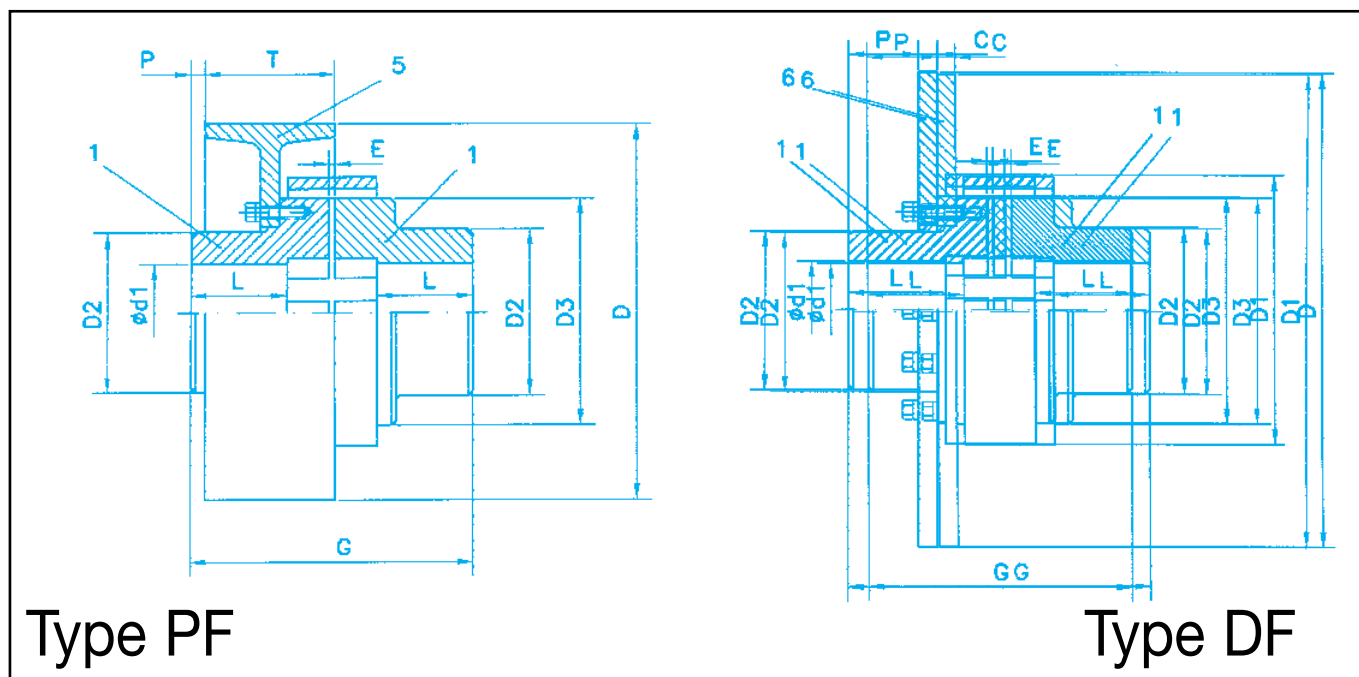

Type PF

Type DF

TYPE	NOMINAL TORQUE Nm	MAX. TORQUE Nm	MAX. BORE d_1 mm.	L mm.	G mm.	D2 mm.	D3 mm.	D mm.	T mm.	P mm.	E mm.	WEIGHT Kg.	J TOTAL Kg. M ²
A4 PF-250	400	1.000	65	63	179	110	150	250	95	15	3,5	28	0,16
A5 PF-315	1.000	2.500	85	77	215	140	190	315	118	10	3,5	54	0,98
A6 PF-315	2.000	4.000	110	95	259	180	233	315	118	25	3,5	78	1,30
A6 PF-400	2.000	4.000	110	95	259	180	233	400	150	20	3,5	99	3,25
A7 PF-500	4.000	8.000	130	116	309	205	267	500	190	25	4	165	5,20
A7 PF-630	4.000	8.000	130	116	309	205	267	630	236	5	5	240	10,45
A8 PF-630	7.500	15.000	150	147	379	242	326	630	236	10	5	310	19,32
A8 PF-710	7.500	15.000	150	147	379	242	326	710	265	5	5	370	20,75
A9 PF-630	12.500	25.000	180	162	418	280	385	630	236	20	5	412	21,65
A9 PF-710	12.500	25.000	180	162	418	280	385	710	265	10	5	445	22,80
A10 PF-710	25.000	40.000	210	188	479	330	483	710	265	25	6	580	25,72

TYPE	NOMINAL TORQUE Nm	MAX. TORQUE Nm	MAX. BORE d_1 mm.	L mm.	G mm.	D1 mm.	D2 mm.	D3 mm.	D mm.	C mm.	P mm.	E mm.	WEIGHT Kg.	J TOTAL Kg. M ²
A4 DF-315	400	1.000	65	63	179	182	110	150	315	16	31	3,5	27	0,152
A5 DF-400	1.000	2.500	85	77	215	225	140	190	400	18	39	3,5	45	0,449
A6 DF-500	2.000	4.000	110	95	259	265	180	234	500	20	50	3,5	78	1,287
A6 DF-630	2.000	4.000	110	95	259	265	180	234	630	30	40	3,5	105	3,291
A7 DF-630	4.000	8.000	130	116	309	306	205	267	630	30	58	4	138	3,675
A7 DF-710	4.000	8.000	130	116	309	306	205	267	710	30	58	4	174	4,013
A8 DF-710	7.500	15.000	150	147	379	363	240	326	710	30	84	5	235	10,842
A8 DF-800	7.500	15.000	150	147	379	363	240	326	800	30	84	5	283	19,431
A9 DF-800	12.500	25.000	180	162	418	425	280	385	800	30	105	5	358	21,129
A9 DF-1000	12.500	25.000	180	162	418	425	280	385	1.000	30	105	5	418	22,355

- REF. 5-6, MATERIAL: DUCTILE IRON GGG-40 / CAST STEEL GS-60.
- REF. 1, MATERIAL: DUCTILE IRON GGG-40.
- FOR PERIPHERAL SPEEDS OF OVER $V=30\text{m/s}$, IT IS NECESSARY TO USE DUCTILE IRON GGG-40.- DYNAMIC BALANCING IS ALSO NECESSARY.

SAMIFLEX FLYWHEEL COUPLINGS

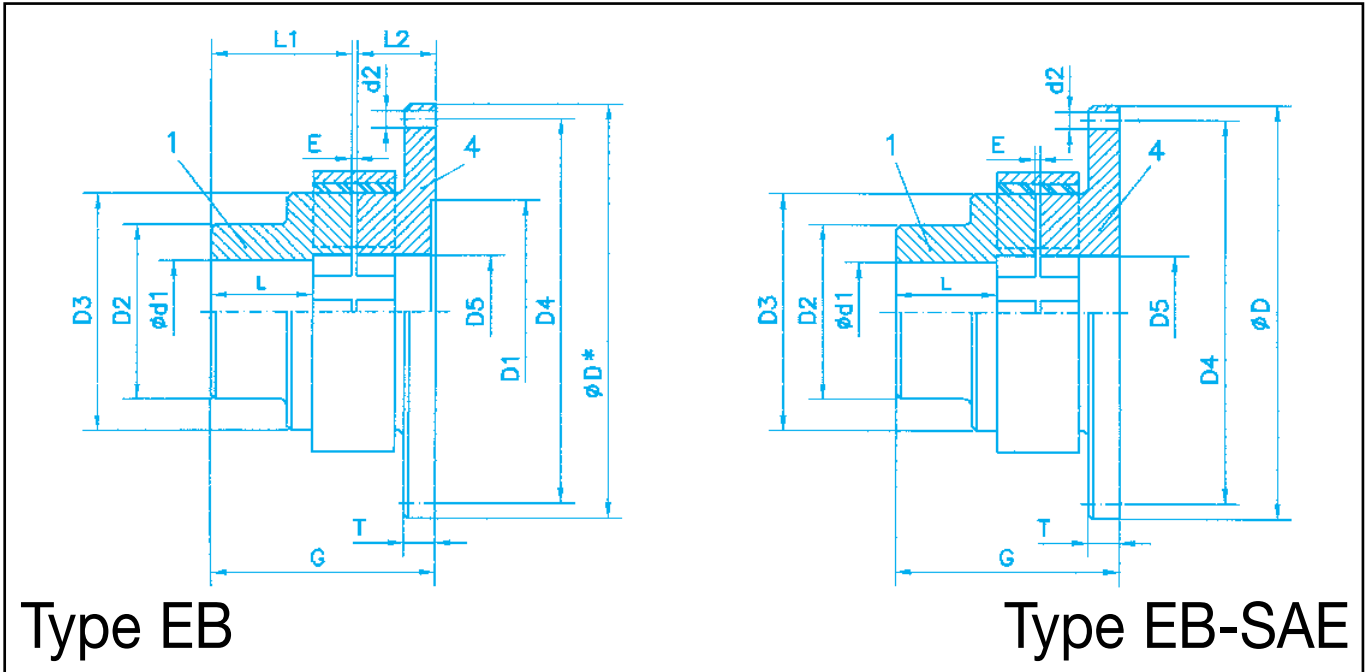

Type EB

Type EB-SAE

TYPE	NOMINAL TORQUE Nm	MAX. TORQUE Nm	MAX. BORE d1 mm.	L mm.	L1 mm.	L2 mm.	G mm.	E mm.	T mm.	D* mm.	D4	d2	D1	D2 mm.	D3 mm.	D5 mm.	WEIGHT Kg.	J TOTAL Kg. M ²
											mm.							
A2 EB	100	250	42	46	62	36	100	2,5	12	265	REFER TO ORDER-SPECIFIC DRAWING			80	86	45	9	0,035
A3 EB	200	500	50	56	76	46	124	2,5	15	315				85	116	55	13	0,110
A4 EB	400	1.000	65	63	88	52	144	3,5	17	360				110	150	75	15	0,230
A5 EB	1.000	2.500	85	76	106	59	168	3,5	20	390				140	190	100	25	0,365
A6 EB	2.000	4.000	110	94	128	65	196	3,5	22	390				180	234	125	43	0,405
A7 EB	4.000	8.000	130	115	153	72	229	4	25	400				205	267	150	61	0,675
A8 EB	7.500	15.000	150	146	189	87	280	5	30	520				240	326	170	105	1,410

TYPE	D h9 mm.	D4 mm.	FLYWHEEL SAE. J620	Z NUM.	d2 mm.	T mm.	D5 mm.	L mm.	G mm.	E mm.	MAX. BORE d1 mm.	D2 mm.	D3 mm.	WEIGHT Kg.	J TOTAL Kg. M ²
A2 EB-SAE	215,9	200,02	6 1/2"	6	9,5	12	45	46	100	2,5	42	80	86	6	0,020
	241,3	222,25	7 1/2"	8	9,58									7	0,024
	263,5	244,47	8"	6	11									9	0,027
A3 EB-SAE	241,3	222,25	7 1/2"	8	9,5	15	55	56	124	2,5	50	85	116	10	0,038
	263,52	244,47	8"	6	11									12	0,050
	314,32	295,27	10"	8	11									13	0,103
A4 EB-SAE	263,52	244,47	8"	6	11	17	75	63	144	3,5	65	110	150	15	0,071
	314,32	295,27	10"	8	11									17	0,130
	352,42	333,37	11 1/2"	8	11									20	0,210
A5 EB-SAE	314,32	295,27	10"	8	11	20	100	76	168	3,5	85	140	190	25	0,172
	352,42	333,37	11 1/2"	8	11									29	0,251
	466,72	438,15	14"	8	14,5									34	0,612
A6 EB-SAE	352,42	333,37	11 1/2"	8	11	22	125	94	196	3,5	110	180	234	37	0,263
	466,72	438,15	14"	8	14,5									45	0,714
	517,52	488,95	16"	8	14,5									53	1,112
A7 EB-SAE	466,72	438,15	14"	8	14,5	25	150	115	229	4	130	205	267	62	0,821
	517,52	488,95	16"	8	14,5									71	1,230
	571,5	542,92	18"	6	18									80	1,924
A8 EB-SAE	517,52	488,95	16"	8	14,5	30	170	146	280	5	150	240	326	115	1,347
	571,5	542,92	18"	6	18									126	2,015
	673,1	641,35	21"	12	18									135	3,681

- REF. 1-4, MATERIAL: CAST IRON GG-25 / DUCTILE IRON GGG-40.
- FOR PERIPHERAL SPEEDS OF OVER V=30m/s IT IS NECESSARY TO USE DUCTILE IRON GGG-40.- DYNAMIC BALANCING IS ALSO NECESSARY.

SAMIFLEX COUPLING FOR TAPER BUSH

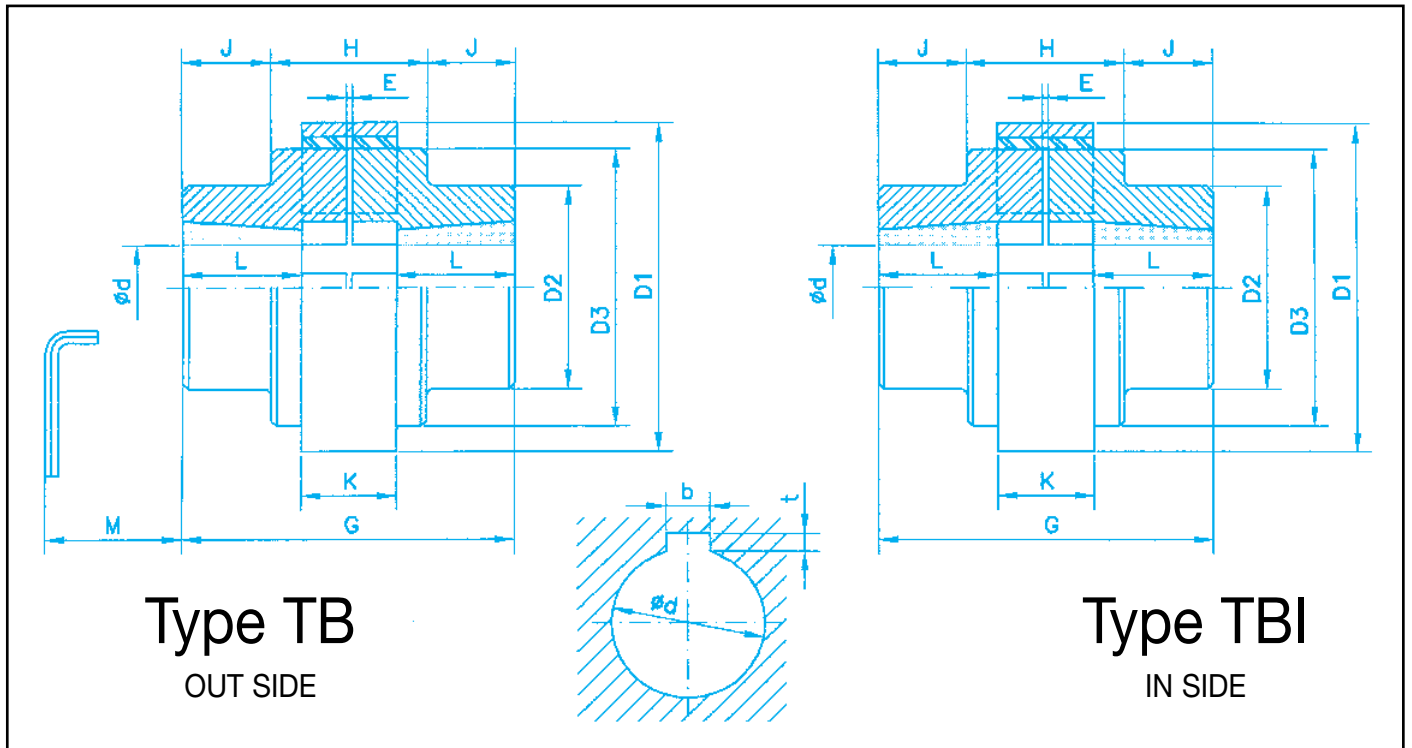

COUPLING TYPE	TAPER BUSH TB	MIN. ød mm.	MAX. ød mm.	L mm.	G mm.	E mm.	K mm.	H mm.	D1 mm.	D2 mm.	D3 mm.	J mm.	M mm.
A1 - TB/TBI	1108	9	28	27	77	1,5	22	-	83	65	65	-	29
A2 - TB/TBI	1210	11	32	32	97	2,5	32	55	111	80	86	21	38
A3 - TB/TBI	1610	14	42	32	107	2,5	42	65	144	85	116	21	38
A4 - TB/TBI	2012	14	50	38	130	3,5	51	85	182	110	150	22	42
A45 - TB/TBI	2517	16	60	50	158	3,5	55	93	202	125	170	32	50
A5 - TB/TBI	3020	25	75	56	173	3,5	59	101	225	140	190	36	55
A6 - TB	3535	35	90	95	259	3,5	67	119	265	180	233	70	67
A7 - TB	4545	55	110	120	318	4	75	134	306	205	267	92	70

DIMENSIONS TAPER-BUSHES																																					
ø d	9	10	11	12	14	16	18	19	20	22	24	25	28	30	32	35	38	40	42	45	48	50	55	60	65	70	75	80	85	90	95	100	105	110			
b	3	3	4	4	5	5	6	6	6	6	8	8	8	8	10	10	10	12	12	14	14	14	16	18	18	20	20	22	22	25	25	28	28	28			
t	1,4	1,4	1,8	1,8	2,3	2,3	2,8	2,8	2,8	3,3	3,3	3,3	3,3	3,3	3,3	3,3	3,3	3,3	3,3	3,8	3,8	3,8	4,3	4,4	4,4	4,9	4,9	5,4	5,4	5,4	5,4	6,4	6,4	6,4			
1108	•	•	•	•	•	•	•	•	•	•	•	•	•																								
1210			•	•	•	•	•	•	•	•	•	•	•	•	•																						
1610					•	•	•	•	•	•	•	•	•	•	•	•	•	•	•	•	•	•	•	•	•	•	•	•	•	•	•	•	•	•	•	•	
2012					•	•	•	•	•	•	•	•	•	•	•	•	•	•	•	•	•	•	•	•	•	•	•	•	•	•	•	•	•	•	•	•	
2517						•	•	•	•	•	•	•	•	•	•	•	•	•	•	•	•	•	•	•	•	•	•	•	•	•	•	•	•	•	•	•	•
3020												•	•	•	•	•	•	•	•	•	•	•	•	•	•	•	•	•	•	•	•	•	•	•	•	•	•
3535																	•	•	•	•	•	•	•	•	•	•	•	•	•	•	•	•	•	•	•	•	•
4545																								•	•	•	•	•	•	•	•	•	•	•	•	•	•

SAMIFLEX FLOATING SHAFT COUPLING

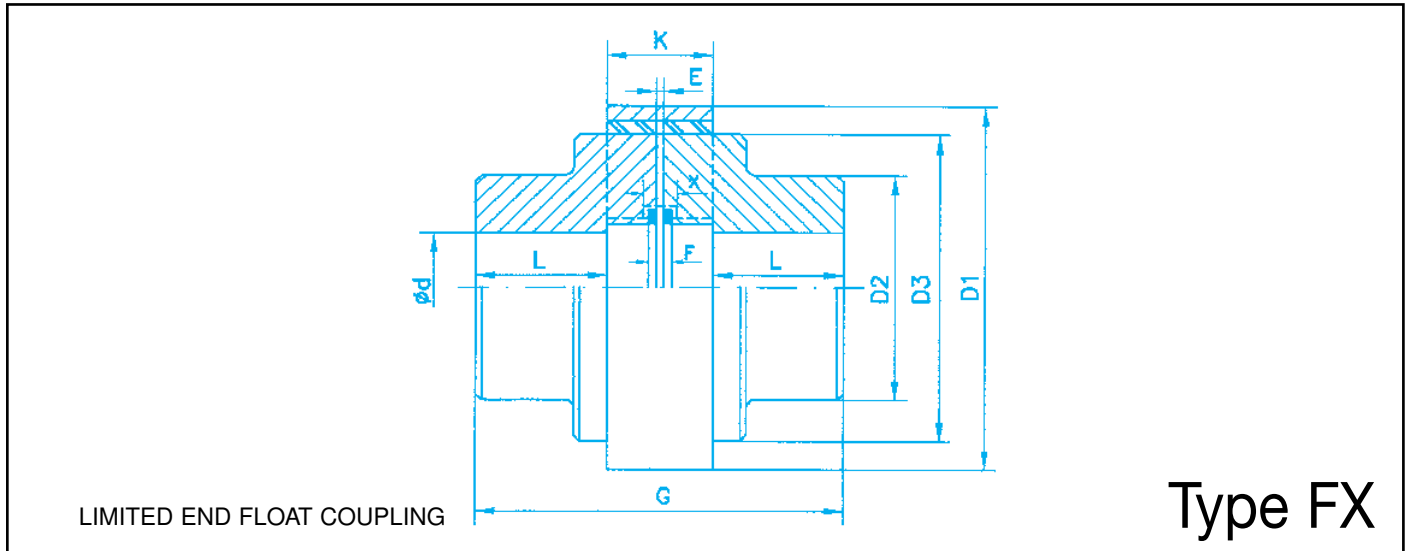

TYPE	NOMINAL TORQUE Nm	MAX. TORQUE Nm	MAX. SPEED R.P.M.	MAX. BORE d	D1 mm.	D2 mm.	D3 mm.	L mm.	K mm.	G mm.	E mm.	F mm.	X mm.
A4 FX	400	1.000	3.500	65	182	110	150	63	51	180	3,5	11,5	12,5
A45 FX	700	1.750	3.100	75	202	125	170	70	56	198	3,5	11,5	12,5
A5 FX	1.000	2.500	2.900	85	225	140	190	77	59	216	3,5	14,5	16,0
A55 FX	1.500	3.000	2.600	95	250	155	215	90	64	246	3,5	14,5	16,0
A6 FX	2.000	4.000	2.500	110	265	180	233	95	67	260	3,5	18,5	20,5
A7 FX	4.000	8.000	2.200	130	306	205	267	116	75	310	4	18,5	20,5
A8 FX	7.500	15.000	1.850	150	363	242	326	147	85	382	5	21,0	24,0
A9 FX	12.500	25.000	1.600	180	425	280	385	162	92	420	5	21,0	24,0
A10 FX	25.000	40.000	1.250	210	523	330	483	188	102	482	6	22,0	26,0

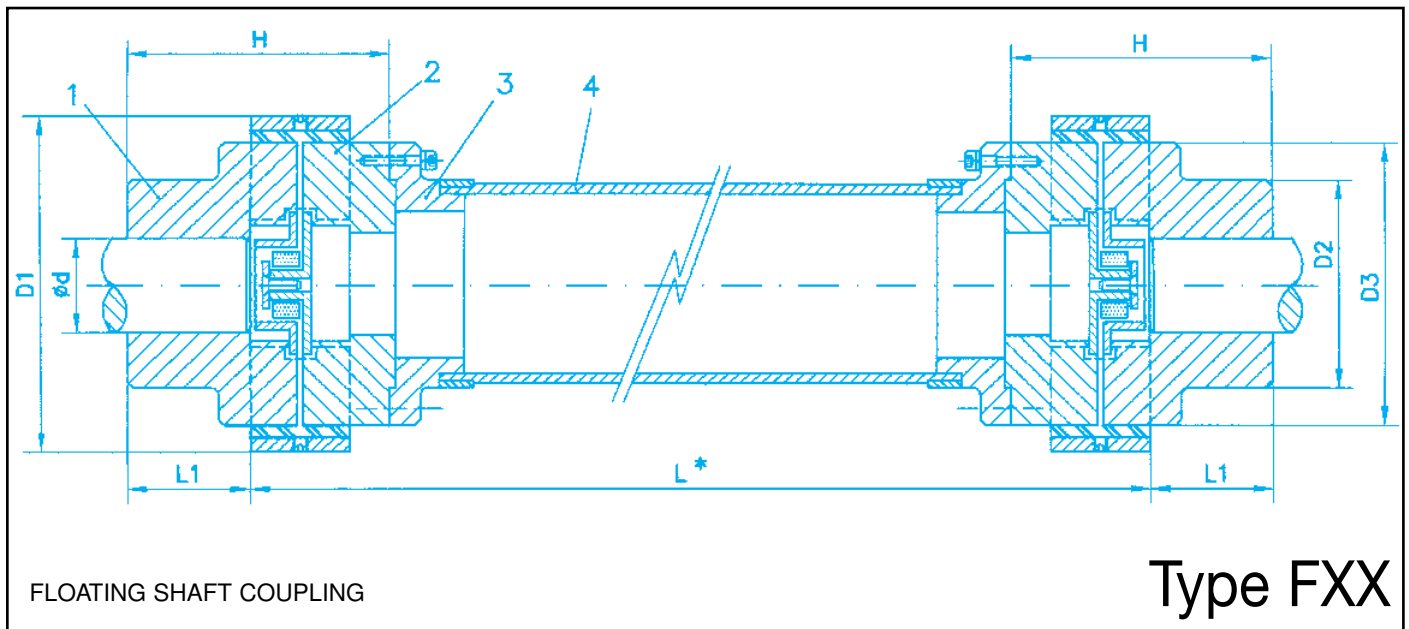

TYPE	NOMINAL TORQUE Nm	MAX. TORQUE Nm	MAX. SPEED R.P.M.	MAX. BORE d	D1 mm.	D2 mm.	D3 mm.	L1 mm.	H mm.	L* MAX. mm.
A4 FXX	400	1.000	1.800	65	182	110	150	63	150	3.400
A45 FXX	700	1.750	1.800	75	202	125	170	70	160	3.400
A5 FXX	1.000	2.500	1.800	85	225	140	190	77	175	4.300
A55 FXX	1.500	3.000	1.800	95	250	155	215	90	195	4.300

- REF. 1-2-3, MATERIAL; ZINC PLATED STEEL (CORROSION RESISTANCE).
- REF. 4, MATERIAL: CARBON FIBRE COMPOSITE OR ZINC PLATED STEEL.
- TYPICAL APPLICATIONS INCLUDE COOLING TOWER DRIVES, AND PAPER MACHINE DRIVES.

INSTRUCTIONS FOR ASSEMBLY OF SAMIFLEX COUPLINGS

1. POSITIONING OF THE PARTS OF THE COUPLING.

Standard coupling hubs, (type A+C) can be positioned on either shaft alike. We recommend putting the flange hub over the drive shaft in couplings with spacer. For couplings with a brakewheel or brakedisc, we recommend putting the hub which houses the wheel or disc, over the shaft of the machine driven.

The couplings hubs are supplied pilot bore. Upon request, we supply the hubs finished bore to ISO tolerances and keyways as per DIN 6885 Standard.

The dynamic balancing of the coupling is made along two planes, quality G 6,3 as per VDI 2060.

The balance is made in couplings with finished bore, and indication must be given as to whether it should be made with or without a keyway.

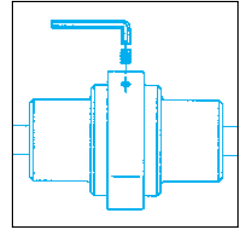

2. RING ASSEMBLY WITH LOCKING SET SCREWS.

With the purpose of keeping the alignment within the maximum admissible tolerances, and in order to prevent the ring slipping axially, it must be fixed to the elastic insert using two set screws inserted through two tapped holes in the retaining ring.

LOCKING SET SCREWS DIMENSIONS FOR RETAINING RINGS

Type	A00	A0	A1	A2	A3	A4	A45	A5	A55	A6	A7	A8	A9	A10	A11
DIN913	-	-	M5	M6	M8	M8	M10	M10	M10	M10	M10	M12	M12	M12	M12
Length	-	-	8	12	12	14	14	14	14	14	16	16	16	18	18

3. ASSEMBLY AND START-UP

For assembly and start-up of the **Samiflex** couplings, please follow our installation instructions in our bulletin, 152/97.

For ATEX requirements, please follow our bulleting 07/2003.

4. SAFETY PROCEDURES

The equipment (motor) must not be started up until the holding ring has been assembled and secured with the locking set screws to the elastic insert.

The elastic insert is projected outwards from the hubs if the equipment (motor) is started up without the holding ring having first been assembled and secured. Coupling guards should be installed prior to start-up.

All rotating equipments are potentially dangerous and can cause serious injury. They must be properly guarded in compliance with standards for the speed and applications in which they are used. It is the responsibility of the user to provide proper guarding accordance with regulations.

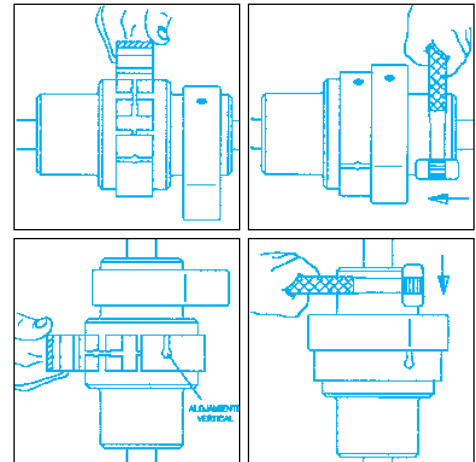

STANDARD KEYWAY DIN 6885 & ISO TOLERANCES

DIMENSIONS DIN 6885					
NOMINAL BORES		KEYWAY bxh	SHAFT t1	BORE t2	TOLERANCE t1/t2
OVER mm.	TO mm.				
6	8	2x2	1,2	1,0	+0,1 0
8	10	3x3	1,8	1,4	
10	12	4x4	2,5	1,8	
12	17	5x5	3,0	2,3	
17	22	6x6	3,5	2,8	
22	30	8x7	4,0	3,3	+0,2 0
30	38	10x8	5,0	3,3	
38	44	12x8	5,0	3,3	
44	50	14x9	5,5	3,8	
50	58	16x10	6,0	4,3	
58	65	18x11	7,0	4,4	
65	75	20x12	7,5	4,9	
75	85	22x14	9,0	5,4	
85	95	25x14	9,0	5,4	
95	110	28x16	10,0	6,4	
110	130	32x18	11,0	7,4	+0,3 0
130	150	36x20	12,0	8,4	
150	170	40x22	13,0	9,4	
170	200	45x25	15,0	10,4	
200	230	50x28	17,0	11,4	

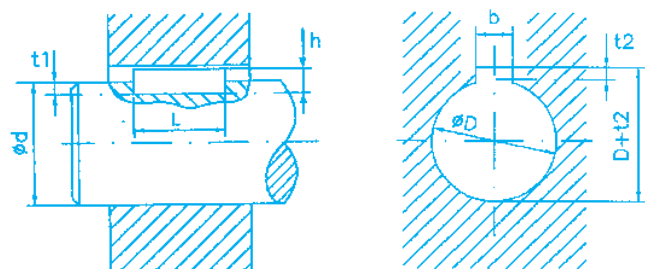

TOLERANCES ISO							
NOMINAL BORE		BORE		SHAFT			
OVER mm.	TO mm.	H7 µm.	H8 µm.	K6 µm.	j6 µm.	g6 µm.	h7 µm.
6	10	+15 0	+22 0	+10 + 1	+ 7 - 2	- 5 -14	0 -15
10	18	+18 0	+27 0	+12 + 1	+ 8 - 3	- 6 -17	0 -18
18	30	+21 0	+33 0	+15 + 2	+ 9 - 4	- 7 -20	0 -21
30	50	+25 0	+39 0	+18 + 2	+11 - 5	- 9 -25	0 -25
50	80	+30 0	+46 0	+21 + 2	+12 - 7	-10 -29	0 -30
80	120	+35 0	+54 0	+25 + 3	+13 - 9	-12 -34	0 -35
120	180	+40 0	+63 0	+28 + 3	+14 -11	-14 -39	0 -40
180	250	+46 0	+72 0	+33 + 4	+16 -13	-15 -44	0 -46

